



**ASAFLEX**™

**Clear Styrenic Copolymer**

**AsahiKASEI**



<b><i>Table of Contents</i></b>	<b><i>Page</i></b>
Fundamentals	2
ASAFLEX™ Grades and Properties	3
ASAFLEX™ Molding and Applications <ul style="list-style-type: none"> <li>-Molding processes and temperatures</li> <li>-Injection molding</li> <li>-Sheet extrusion</li> <li>-Film extrusion</li> <li>-Profile extrusion</li> <li>-Blow molding</li> </ul>	4–7
ASAFLEX™ Characteristics <ul style="list-style-type: none"> <li>-Low-temperature impact strength</li> <li>-Heat distortion resistance</li> <li>-Weatherability</li> <li>-Gas permeability</li> <li>-Chemical resistance</li> <li>-Hinge capability</li> <li>-Gamma-ray resistance</li> <li>-Comparison with other transparent resins</li> <li>-Conformity with food-hygiene requirements</li> </ul>	8–12
Blended ASAFLEX™ Properties <ul style="list-style-type: none"> <li>-Transparency</li> <li>-Impact strength</li> <li>-Low temperature impact strength</li> <li>-Gas permeability</li> </ul>	13–17
Important Notes and Precautions	18

# Fundamentals

## What is ASAFLEX™?

The *ASAFLEX™* polymer chain is composed of alternating styrene and butadiene blocks. The styrene blocks impart rigidity and high compatibility with other styrenic resins. The butadiene blocks, with their fine dispersion, provide high impact strength.

With this block copolymer composition, *ASAFLEX™* is suitable for molding, extruding, and forming processes, either alone or in blended form, for products ranging from food and cosmetics containers to shrink labels and blister packaging.

## Morphology of ASAFLEX™

In *ASAFLEX™* resins, as shown in the lower-left micrograph, the butadiene-phase (i.e., the rubber-phase) dispersion is on a finer scale than the wavelength of visible light. Therefore, *ASAFLEX™* can effectively improve the impact strength, flexural properties, and other copolymer characteristics, without any effect on light transmission.

In HIPS (high impact polystyrene), in contrast, the butadiene-phase dispersion resembles large "salami" cross-sections, which tend to block light and thus make the resins opaque.

*ASAFLEX™* and HIPS micrographs : butadiene appears dark, styrene light.

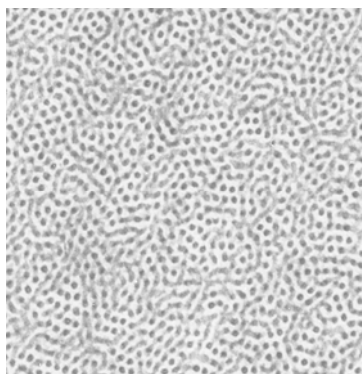

*ASAFLEX™* - transparent

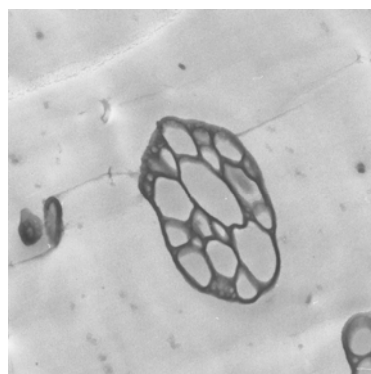

*HIPS* - opaque

## Salient features of ASAFLEX™

High transparency
Excellent impact strength
High compatibility with other styrenic resins
Excellent coloring and printing qualities
Elegant gloss
Excellent hinge properties
Conformity with food hygiene requirements

# ASAFLEX™ Grades and Properties

Property	Test method	Units	805	810	825	830	840
					815 (with wax)	835 (with wax)	845 (with wax)
Density	ISO 1183	kg/m <sup>3</sup>	1.02x10 <sup>3</sup>	1.01x10 <sup>3</sup>	1.02x10 <sup>3</sup>	1.01x10 <sup>3</sup>	1.02x10 <sup>3</sup>
Water absorption	ISO 62	%	< 0.1	< 0.1	< 0.1	< 0.1	< 0.1
MFR (200°C, 5kgf)	ISO 1133	g/10 min	10	5	6	5	7
Mold shrinkage	—	%	0.2~0.8	0.2~0.8	0.2~0.8	0.2~0.8	0.2~0.8
Tensile strength* <sup>1</sup>	ISO 527-1	MPa	30	20	27	18	27
Elongation* <sup>1</sup>		%	15	250	200	250	40
Flexural strength	ISO 178	MPa	50	24	37	21	34
Flexural modulus		MPa	1550	1400	1200	1100	1500
Rockwell hardness	ISO 2039-2	R scale	88	< 10	55	< 10	< 10
Durometer hardness	ISO 868	D scale	75	62	71	55	68
Charpy impact strength unnotched* <sup>2</sup>	ISO 179	kJ/m <sup>2</sup>	16	NB	100	NB	NB
Charpy impact strength V-notched* <sup>2</sup>		kJ/m <sup>2</sup>	1.3	P	2	P	2
Heat distortion temp.* <sup>3</sup>	ISO 75-1	°C	63	65	57	60	62
Vicat softening point* <sup>4</sup>	ISO 306	°C	91	83	82	72	81
Total light transmission* <sup>5</sup>	ISO 13468	%	90	89	90	89	88
Haze* <sup>5</sup>	ISO 14782	%	0.5	1.2	0.5	2	1.2
Key advantages			-Transparency -Stiffness -Surface hardness	-Compatibility with styrenics -Impact strength -Hinge capability	-Transparency -Low anisotropy -Impact strength -Thermal stability	-Impact strength -Excellent properties balance	-Compatibility with GPPS -Excellent properties balance
Recommended molding process	Injection molding		◎	-	◎	○	○
	Extrusion		-	◎	◎	◎	◎
	Blow molding		-	-	◎	-	-
Typical applications			-Cosmetics caps -Food containers	-Cosmetics caps -Food containers	-Blister packaging -laminates/ shrink labels	-Blister packaging -Shrink labels	-Laminate/ shrink labels -Drink cups -Food containers -Gardening ampoules

\*<sup>1</sup> At 5 mm/min for ASAFLEX™ 805 and 50 mm/min for all other grades. \*<sup>2</sup>Value at fracture into two or more pieces  
NB: non-break at 15 J, P: partial break at 15 J. \*<sup>3</sup>Non-annealed, 1.8 MPa load, 3 mm width. \*<sup>4</sup>10 N load, 50 K/h.  
\*<sup>5</sup>2 mm plate.

Please note that all data and values are given as typical results obtained with the indicated test methods for purposes of basic reference in grade selection only, and not as any product specification or warranty of any nature, and are subject to change without notice.

# ASAFLEX™ Molding and Applications

## Molding Processes and Temperatures

ASAFLEX™ can be used in any of the molding processes generally employed for thermoplastic polymers, as indicated in the following chart, which provides a basic guideline on optimal and practicable molding temperature ranges of ASAFLEX™.

Temperature is generally the key consideration. Temperatures of 250°C or higher are generally inappropriate, as ASAFLEX™ will tend to cause rapid crosslinking in the butadiene (rubber) phase, loss of transparency, and other properties degradation. For operations which may involve long retention times, temperatures as low as 230°C may cause similar problems and require particular care.

Because of its low water absorption, ASAFLEX™ ordinarily requires no pre-drying.

ASAFLEX™ molding temperatures\* - optimal ( — ) and practicable ( - - - )

Molding process	Molding temperature (°C)										
	100	120	140	160	180	200	220	240	260		
Injection molding						—	—	—	—	—	
Injection blow molding						—	—	—	—	—	
T-die extrusion						—	—	—	—	—	
Blown-film extrusion						—	—	—	—	—	
Blow molding						—	—	—	—	—	
Compression molding						—	—	—	—	—	
Vacuum forming											
Pressure forming											

\*The ranges shown are for ASAFLEX™ regular grades.

### Important note on grades with wax - ASAFLEX™ 815, 835, and 845

The use of ASAFLEX™ grades with wax may result in surface whitening and opacity in extruded sheets, films, and other products, due to wax blooming. This tendency varies with resin formulations, extruding conditions, and conditions of product storage and use. It is therefore essential to perform advance trials before using any ASAFLEX™ grade with wax, to confirm that the degree of wax blooming will be acceptable for the intended product application.

# ASAFLEX™ Molding and Applications

## Injection molding

Injection molded ASAFLEX™ provides both superior transparency and high impact strength, as well as coloring and printing capabilities. ASAFLEX™ is widely used both alone and in polystyrene blends, to produce food containers, mousse can caps, cases, toys, and many other products for household use.



### Key advantages

Transparency and impact strength
Low-temperature impact strength
Push-lock effect
Hinge capability
Dull-edged fragmentation
Coloring and printing capabilities
Polystyrene compatibility and strengthening
Conformity with food-hygiene require-

### Typical molding conditions

Flat plate	130 x 110 x 3 mm
Gate	Tab gate, 3 x 3 mm
Machine	5 oz, 80 ton clamp force
Cylinder temp.	180–200°C
Nozzle temp.	200°C
Injection press.	680 kgf/cm <sup>2</sup>
Mold temp.	50°C
Back press.	60 kgf/cm <sup>2</sup>
Cushion	3–5 mm
Injection time	10 sec
Cooling time	20 sec

## Applications

*Dessert cups, garment hangers, toys, cases, cosmetics overcaps, other parts and products*



Edges less sharp when fragmented



Excellent hinge properties



Low-temp. impact strength



# ASAFLEX™ Molding and Applications

## Sheet extrusion

Styrenic sheets extruded from ASAFLEX™ blends with GPPS, SC™ polymer\*<sup>1</sup>, and other styrenic resins provide special properties in addition to those of ASAFLEX™ alone, in blend ratios selected for the appropriate combination of transparency and impact strength. TUFPRENE™ \*<sup>2</sup> further increases toughness and impact strength, especially at low temperatures.



### Key advantages

Transparency and impact strength
Low-temperature impact strength
Deep-draw capability
Elegant gloss
Coloring and printing capabilities
Free of chlorine gas generation
Density lower than rigid PVC and A-PET
Compliance with food-hygiene requirements

### Typical extrusion conditions

T-die extruded sheet	0.8 mm thickness, 700 mm width	
Extruder diameter	90 mm Φ	
Screw	Full-flight, L/D = 28	
Die	Coat-hanger type	
Cylinder temp.	C1	170°C
	C2	180°C
	C3	185°C
	C4	190°C
	C5	200°C
Die temperature D1~D5	200°C	
Polishing roller temperature	60~80°C	

Deep-draw capability



### Applications

*Blister packaging, clear drink cups, food containers, egg cartons, IC carrier tapes*

Stacking capability



Low-temp. impact strength

\*<sup>1</sup> SC™ Polymer: Styrenic copolymer from PS Japan Corp. Similar to ASAFLEX™ in refraction index, for sheet transparency significantly higher than attainable with any GPPS.

\*<sup>2</sup> TUFPRENE™: Styrenic thermoplastic elastomer from Asahi Kasei Chemicals Corp. Increases sheet impact strength and other properties, in blends with ASAFLEX™.

### Important note on grades with wax – ASAFLEX™ 815, 835, and 845

The use of ASAFLEX™ grades with wax may result in surface whitening and opacity in extruded sheets, films, and other products, due to wax blooming. This tendency varies with resin formulations, extruding conditions, and conditions of product storage and use. It is therefore essential to perform advance trials before using any ASAFLEX™ grades with wax, to confirm that the degree of wax blooming will be acceptable for the intended product application.

# ASAFLEX™ Molding and Applications

## Film extrusion

ASAFLEX™ blends with GPPS and other styrenics, enables the extrusion of styrenic films and laminating films with special qualities.



### Key advantages

High transparency
Elegant gloss
Thermal lamination with styrenic-sheets
Coloring and printing capabilities
Oxygen, water-vapor permeability / breathability

## Typical application

### Shrink labels



### Laminated-film food packaging



## Profile extrusion

ASAFLEX™ alone and in blends enables efficient extrusion of transparent parts in a wide variety of shapes, functions, and applications.



### Key advantages

High transparency
High folding endurance
Excellent extrudability
Superior rigidity
Density lower than rigid PVC and PET

## Typical application

### IC Magazine rail



## Blow molding

ASAFLEX™ alone and in blends enables both direct and injection blow molding, for a wide variety of containers and other products.



### Key advantages

High transparency
Low-temperature impact strength
Excellent moldability
Excellent printing and coloring characteristics

## Typical applications

### Glue containers, Gardening ampoules



# ASAFLEX™ Characteristics

## Low-temperature impact strength

ASAFLEX™ is inherently higher than GPPS in impact strength, particularly at low temperatures. Sheets with outstanding low-temperature impact strength can be obtained by increasing the ASAFLEX™ content in blends with SC™ polymer\*<sup>1</sup> and other styrenics.

### Low-temperature impact strength of ASAFLEX™ /GPPS blend

Test piece		Dart impact strength (J)		Izod impact strength, unnotched (kJ/m <sup>2</sup> )	
		23°C	-30°C	23°C	-30°C
ASAFLEX™ 810	3 mm plate	>15	>15	non-break	non-break
GPPS		0.3	<0.3	9	8
ASAFLEX™810/ GPPS(60/40)	0.75 mm sheet	>15	10	-	-

### Low-temperature impact strength of ASAFLEX™/ SC™ blends

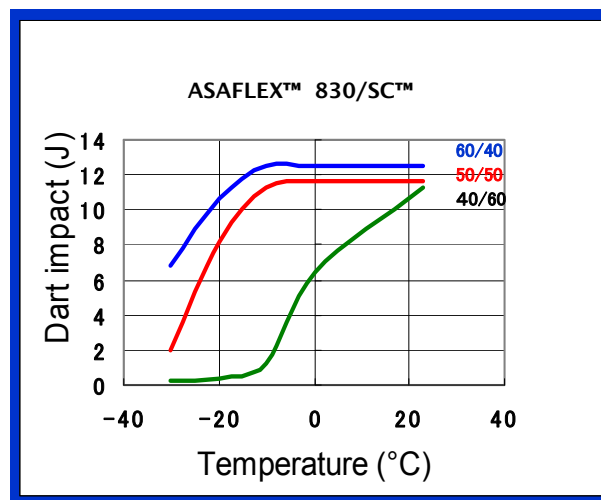

Sheet thickness: 0.6 mm, Dart tip: 1/2 inch

\*<sup>1</sup> SC™ Polymer: Styrenic copolymer from PS Japan Corp. Similar to ASAFLEX™ in refraction index, for sheet transparency significantly higher than attainable with any GPPS.

Please note that all data and values are given as typical results obtained with the indicated test methods for purposes of basic reference in grade selection only, and not as any product specification or warranty of any nature, and are subject to change without notice.

# ASAFLEX™ Characteristics

## Heat distortion resistance

The ASAFLEX™ heat distortion temperatures, shown below, provide an approximate guide to the practical upper temperature limits of ASAFLEX™ end applications.

### ASAFLEX™ heat distortion temperatures under load<sup>\*1</sup>

Regular grades				
805	810	825	830	840
		815 (with wax)	835 (with wax)	845 (with wax)
63°C	65°C	57°C	60°C	62°C

<sup>\*1</sup>ISO 75-1

## Weatherability

ASAFLEX™ is not weather resistant, due to the presence of the C=C bonds in its main-chain butadiene blocks. The use of ASAFLEX™ for outdoor applications is therefore generally not recommended.

## Gas permeability

ASAFLEX™ is permeable to oxygen and water vapor, and is therefore effective for wrapping fresh vegetables and other applications requiring breathability and /or long term durability.

### ASAFLEX™ permeability, comparison with HIPS and GPPS

Property	Test method	Units	ASAFLEX™ 810	HIPS	GPPS*
Sheet thickness	-	mm	0.35	0.34	0.30
Water-vapor permeability	JIS Z0280 B	g/m <sup>2</sup> , 24 hr	14	14	12
Oxygen permeability	Modern Control Ox-Train 100	cc/m <sup>2</sup> , 24 hr	1500	560	370

\*biaxially oriented sheets.

Please note that all data and values are given as typical results obtained with the indicated test methods for purposes of basic reference in grade selection only, and not as any product specification or warranty of any nature, and are subject to change without notice.

# ASAFLEX™ Characteristics

## Chemical resistance

ASAFLEX™ is similar to polystyrene in its chemical and oil resistance, as shown below.

Chemical, oil	Test result*1 *2	Chemical, oil	Test result*1 *2
<b>Inorganic acids</b>		<b>Esters</b>	
weak acid	◎	ethyl acetate	×
strong acid	◎	butyl acetate	×
oxidizing strong acid	△~×	DBP	×
<b>Inorganic bases</b>		DOP	×
weak base	◎	DOA	×
strong base	◎~○	MMA	×
<b>Inorganic salts</b>		<b>Halogenated hydrocarbons</b>	
neutral salt	◎	chloroform	×
<b>Aliphatic hydrocarbons</b>		carbon tetrachloride	×
n-hexane	△	trichloroethane	×
n-heptane	△	trichloroethylene	×
cyclohexane	×	tetrachloroethylene	×
<b>Aromatic hydrocarbons</b>		chlorobenzene	×
toluene	×	<b>Inorganic acids</b>	
xylene	×	acetic acid	△
<b>Alcohols</b>		propionic acid	△
ethyl alcohol	◎~○	<b>Mineral oils</b>	
n-propyl alcohol	◎	paraffinic oil	△
i-propyl alcohol	◎	naphthenic oil	△
ethylene glycol	◎	aromatic oil	×
glycerol	◎	<b>Vegetable oils</b>	
<b>Ketones</b>		soybean oil	◎~○
acetone	×	rapeseed oil	◎~○
methyl ethyl ketone	×	cottonseed oil	◎~○
<b>Ethers</b>		<b>Others</b>	
diethyl ether	×	soy sauce	◎
ethyl cellosolve	×	butter	△
polyethylene glycol	◎	synthetic detergent	○

\*1 Test conditions: 20°C, 7-day immersion

\*2 Symbols: ◎no change, ○slight haze, △haze, microcrack  
 × unusable due to swelling, dissolution, cracking, etc.

# ASAFLEX™ Characteristics

## Hinge capability

ASAFLEX™ combines excellent transparency, hinge formation and durability, and superior push-lock effects. Several grades, such as 825 shown at left, provide extra resistance to hinge whitening.

### ASAFLEX™ hinge durability - repetitions to fracture

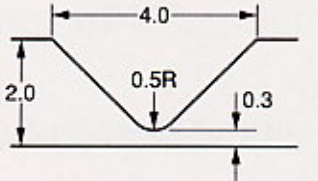
Hinge design (dimensions in mm)	805	810	825
	1,200	42,000	10,000

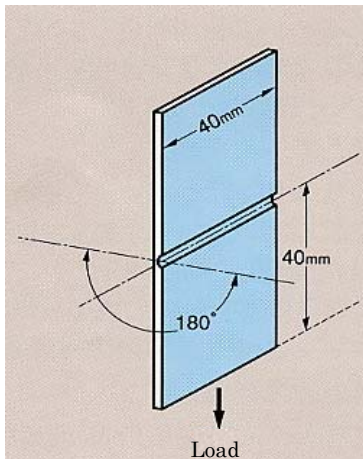

**Test conditions:** Bending angle:180°, bending rate:100 cycles per min, load:500g, pre-test plate-bending treatment:none.

### Typical products with hinge



## Gamma-ray resistance

ASAFLEX™ is largely unaffected by gamma-ray sterilization, in medical and other applications.

Gamma-ray exposure (Mrad)	ASAFLEX™ 805			ASAFLEX™ 815		
	Tensile strength	Elongation	Transparency	Tensile strength	Elongation	Transparency
0	100	100	100	100	100	100
2.5	100	100	100	100	100	100
5	100	100	100	100	100	100

(Post-exposure values are shown here as percentage of values prior to gamma-ray exposure.)

Please note that all data and values are given as typical results obtained with the indicated test methods for purposes of basic reference in grade selection only, and not as any product specification or warranty of any nature, and are subject to change without notice.

\*For any applications involving extended bodily contact or medical device and containers, contact Asahi Kasei Chemicals Corporation.

# ASAFLEX™ Characteristics

## Comparison with other transparent resins

ASAFLEX™ is superior to all other transparent resins in its overall balance of physical properties, as shown in the following comparison.

	ASAFLEX™	GPPS	SAN	ABS* <sup>1</sup>	PMMA	PC* <sup>2</sup>	PP* <sup>3</sup>
Transparency	○	○	○	△	◎	○	X
Impact strength (room temp.)	○~◎	X	△	◎	△	◎	○
Impact strength (low temp.)	○~◎	X	X	◎	X	◎	△
Stiffness	△~○	◎	◎	○	◎	○	△
Weather resistance	△	○	○	△	◎	○	○
Hinge capability	○~◎	X	X	△	X	X	◎

\*<sup>1</sup> Transparent ABS    \*<sup>2</sup> Polycarbonate    \*<sup>3</sup> Transparent polypropylene

**Symbols: ◎Excellent, ○Good, △Somewhat inferior, ×Inferior**

*Note: All tests were performed with standard resin grades under the same test conditions.*

## Conformity with food-hygiene requirements

ASAFLEX™ Grades	Positive list of JHOSPA* <sup>1</sup>	FDA	Commission Directive 2002/72/EC* <sup>2</sup>
805	○	21 CFR §177.1640	○
810	○	21 CFR §177.1810	○
815	○	21 CFR §177.1640	○
825	○	21 CFR §177.1640	○
830	○	×	○
835	○	×	○
840	○	21 CFR §177.1640	○
845	○	21 CFR §177.1640	○

\*<sup>1</sup> JHOSPA : Japan Hygienic Olefin and Styrene Plastics Association

\*<sup>2</sup> Commission Directive 2002/72/EC relating to plastic materials and articles intended to come into contact with foodstuffs

# Blended ASAFLEX™ Properties

The inherent ASAFLEX™ compatibility and performance characteristics facilitate its blending with polystyrene, SC™ polymer\*<sup>1</sup>, MS\*<sup>2</sup>, and other styrenic resins, for specific advantages and performance profiles. TUFPRENE™\*<sup>3</sup> can add higher impact strength and other key advantages.

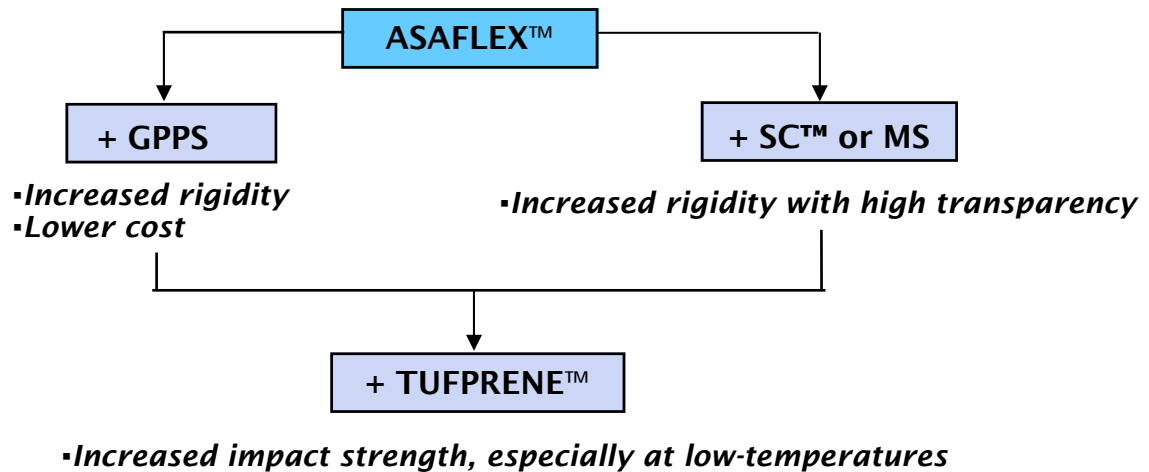

- \*<sup>1</sup> **SC™ Polymer** : Styrenic copolymer from PS Japan Corp. Similar to ASAFLEX™ in refraction index, for sheet transparency significantly higher than attainable with any GPPS.
- \*<sup>2</sup> **MS** : Transparent methylmethacrylate-styrene copolymer.
- \*<sup>3</sup> **TUFPRENE™** : Asahi Kasei Chemicals Corp. styrenic thermoplastic elastomer. Increases sheet impact strength and other properties, in blends with ASAFLEX™

## Blend sheet transparency

ASAFLEX™ blends with SC™ enable substantially higher sheet transparency than those with GPPS.

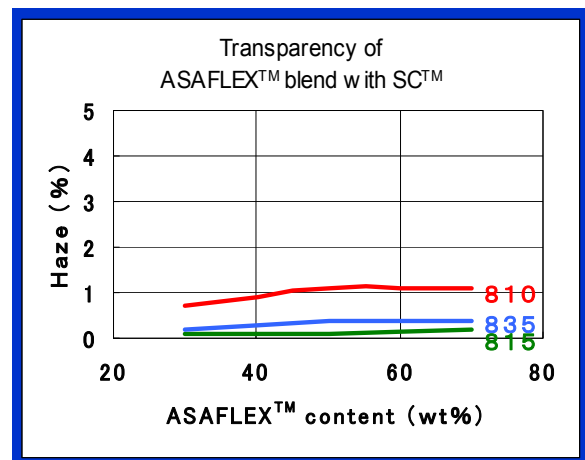
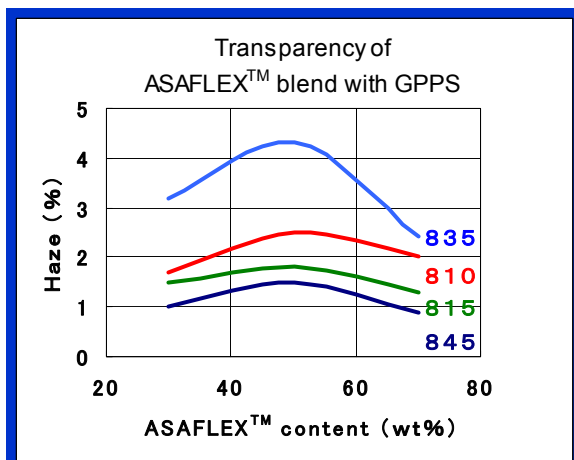

Please note that all data and values are given as typical results obtained with the indicated test methods for purposes of basic reference in grade selection only, and not as any product specification or warranty of any nature, and are subject to change without notice.

# Blended ASAFLEX™ Properties

## Blend sheet impact strength

Impact strength of ASAFLEX™/polystyrene blended sheets generally increases with increasing ASAFLEX™ content, as shown here for both ASAFLEX™/GPPS and ASAFLEX™/SC™ blends. Transparency is generally higher with SC™ than with GPPS.

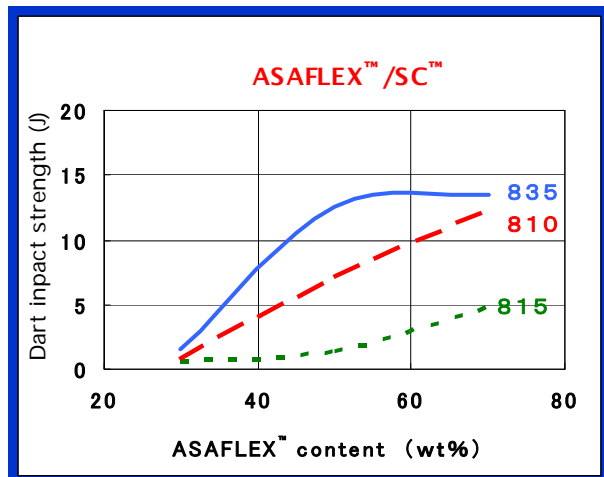
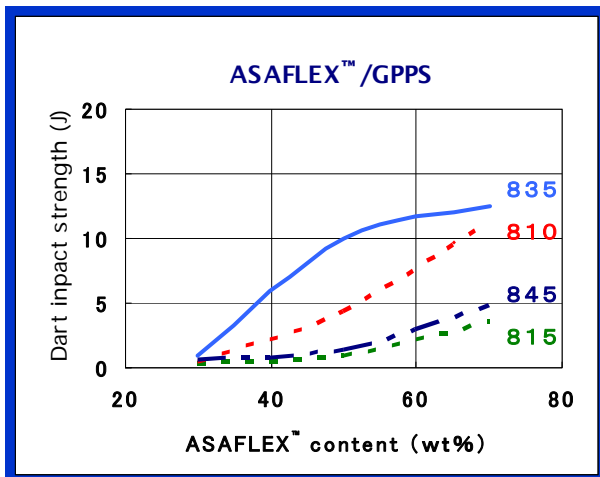

Three-way blends, with TUFPRENE™ partially replacing the ASAFLEX™ component, further increases the impact strength, as shown here, with only a small loss in transparency.

Conversely, adding TUFPRENE™ into ASAFLEX™/GPPS two way blends can be useful for cost reduction. By adding TUFPRENE™, which is very effective as a impact strength modifier, into the original two way blend, the total content of ASAFLEX™ and TUFPRENE™ needed to realize the same impact strength with the original blend is smaller than the content of ASAFLEX™ alone in the original blend.

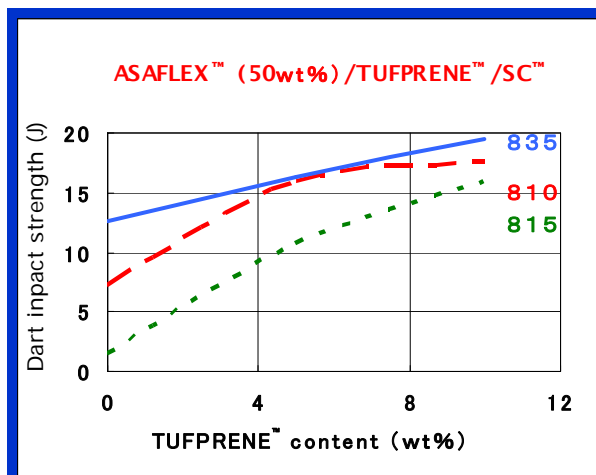
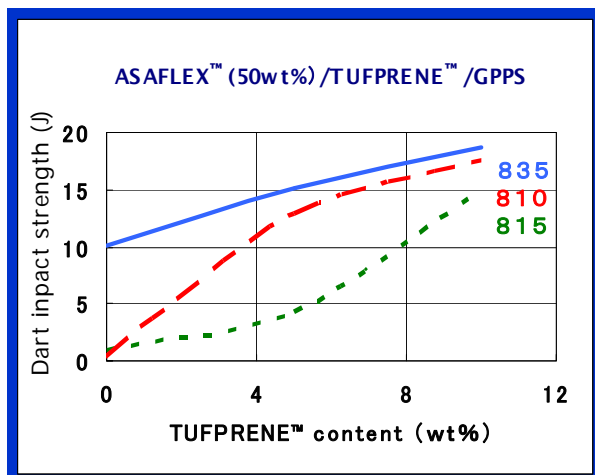

Please note that all data and values are given as typical results obtained with the indicated test methods for purposes of basic reference in grade selection only, and not as any product specification or warranty of any nature, and are subject to change without notice.

# Blended ASAFLEX™ Properties

## Blend sheet low-temperature impact strength

Among ASAFLEX™ series, ASAFLEX™ 835 has the highest low-temperature impact strength. However, the impact strength at low temperature which is required for frozen containers is difficult to be met using the two-way blends with styrenics. Acquiring higher low temperature resistance is possible by three-way blends, utilizing TUFPRENE™.

### ASAFLEX™ / SC™ / TUFPRENE™ blend

With the three way blends of ASAFLEX™ / SC™ / TUFPRENE™, material design with superior low-temperature impact strength and transparency is possible.

		835/SC™/TUFPRENE™			Reference		
Composition	ASAFLEX™ 835		50	50	50	50	
	SC™ Polymer*1		45	40	35	-	
	GPPS		-	-	-	45	
	TUFPRENE™		5	10	15	5	
Property		Condition	Units				
	Dart impact strength	23°C	J	>20	19	19	18
		-20°C		>20	>20	>20	>20
		-30°C		12	20	>20	9
		-40°C		10	11	17	3
	Total light transmission		%	98.6	98.1	97.3	90.7
	Haze		%	1.3	1.6	2.2	4.7
	Tensile strength	MD	MPa	23	18	15	24
		TD		13	11	9	15
	Elongation	MD	%	125	205	270	160
		TD		>300	>300	>300	>300
	Tensile modulus	MD	MPa	1660	1370	1240	1760
TD		950		740	540	970	
	Average	MPa	1300	1060	890	1370	

\*1 SC™ Polymer: styrenic copolymer from PS Japan Corp.

Please note that all data and values are given as typical results obtained with the indicated test methods for purposes of basic reference in grade selection only, and not as any product specification or warranty of any nature, and are subject to change without notice.

# Blended ASAFLEX™ Properties

## ASAFLEX™/GPPS/TUFPRENE™ blend

In ASAFLEX™/GPPS blends, the rigidity, transparency and impact strength of the sheet can be controlled through different blending ratios, according to the requirements of the end application.

					835/SC™ <sup>1</sup> /TUFPRENE™			835/GPPS	
Composition	ASAFLEX™835			50	50	50	50	70	
	GPPS			45	40	35	50	30	
	TUFPRENE™			5	10	15	0	0	
Property		Condition	Units						
	Dart impact strength	23°C	J	18	>20	>20	6	17	
		-20°C		>20	>20	>20	-	-	
		-30°C		9	20	>20	-	-	
		-40°C		3	6	8	-	-	
	Total light transmission		%	90.7	86.4	83.2	94	95	
	Haze		%	4.7	6.6	8.5	2.1	1.7	
	Tensile strength	MD	MPa	24	20	15	32	24	
		TD		15	13	10	18	12	
Elongation	MD	%	160	215	260	60	200		
	TD		>300	>300	>300	160	>300		
Tensile modulus	MD	MPa	1760	1640	1230	1560	1330		
	TD		970	740	550	1110	740		

\*1 SC™ Polymer: styrenic copolymer from PS Japan Corp.

Please note that all data and values are given as typical results obtained with the indicated test methods for purposes of basic reference in grade selection only, and not as any product specification or warranty of any nature, and are subject to change without notice.

# Blended ASAFLEX™ Properties

## Blend sheet gas permeability

By blending with styrenic resins, ASAFLEX™ is capable of controlling the stiffness and gas permeability while keeping the transparency and elongation.

Property* <sup>2</sup>	Units	825/SC™ Polymer* <sup>1</sup> blend ratio					LDPE (reference)
		100/0	70/30	50/50	30/70	0/100	
O <sub>2</sub> permeability	* <sup>3</sup>	10000	8500	7600	6600	5100	7500
CO <sub>2</sub> permeability	* <sup>4</sup>	13000	10000	8000	6000	2600	14000
Total light trans.	%	99	99	99	99	99	98
Haze	%	0.2	0.3	0.6	0.3	0.2	6.5
Tensile Modulus	MPa	1000	1510	1890	2320	2630	160
Tensile Strength	MPa	18	23	28	38	36	9
Elongation (TD)	%	300	300	300	250	1.5	300
Water-vapor permeability	* <sup>5</sup>	11	10	10	10	10	3

\*<sup>1</sup> SC Polymer : styrenic copolymer from PS Japan Corp.

\*<sup>2</sup> 0.3mmT sheet. Tensile modulus, Tensile Strength: Average of MD and TD

\*<sup>3</sup> CC . 25.µm/m<sup>2</sup>/day/atm at 23°C, 65RH (equal-pressure method)

\*<sup>4</sup> CC . 25.µm/m<sup>2</sup>/day/atm at 23°C, 65RH (equal-pressure method)

\*<sup>5</sup> CC . 25.µm/m<sup>2</sup>/day/atm at 40°C, 90RH (equal-pressure method)

Please note that all data and values are given as typical results obtained with the indicated test methods for purposes of basic reference in grade selection only, and not as any products specification or warranty of any nature, and are subject to change without notice.

# Important Notes and Precautions

All information, data, and values contained herein are given as a representation in good faith of results obtained by the indicated test methods and of data, information, and documents currently available to Asahi Kasei Chemicals Corporation (AKCC), for use only as a basic guide to grade selection for various applications and not as any explicit or implied warranty or guarantee of any nature, and are subject to change in accordance with changes in product properties and new findings or knowledge.

## Safe handling and use

Always observe the following general precautions and consult the Material Safety Data Sheets (MSDS) issued by AKCC before handling or using ASAFLEX™ and investigate and determine by advance testing the safety and suitability of any addition or mixing of any other resin, additive, or other materials. It is the responsibility of the user to determine the safety and suitability of ASAFLEX™ for the intended use, purpose, and application.

### *Hot or molten polymer*

Avoid inhalation and eye or skin contact with any gases generated in heating or melting ASAFLEX™ and with the hot or molten polymer. Employ local ventilation and protective gear, including chemical goggles and protective gloves, during any heating or melting operation.

### *Combustibility*

ASAFLEX™ is flammable and must be kept strictly away from heat, sparks, and flame during handling and storage. In the event of its combustion, carbon monoxide and other toxic combustion gases may be generated; extinguish with water or with foam or dry chemical extinguisher.

## Disposal

Dispose of ASAFLEX™ in accordance with local and national law and regulations, by burning in a properly equipped incinerator or by burial in a properly designed landfill site. Note that carbon monoxide and other toxic gases may be generated during incineration. Do not release to sewers, ground, or any body of water.

## Storage

Store ASAFLEX™ in a cool dark area away from direct sunlight, humidity, and moisture.

## Molding conditions

Appropriate temperatures and other conditions for the molding and extruding of ASAFLEX™ vary with the resin grade and type of use. Consult AKCC for its representatives for related information.

## Important note on grades with wax – ASAFLEX™ 815, 835, and 845

The use of ASAFLEX™ grades with wax may result in surface whitening and opacity in extruded sheets, films, and other products, due to wax blooming. This tendency varies with resin formulations, extruding conditions, and conditions of product storage and use. It is therefore essential to perform advance trials before using any ASAFLEX™ grade with wax, to confirm that the degree of wax blooming will be acceptable for the intended product application.

## Hygienic standards

Certain ASAFLEX™ grades comply with hygienic standards. For any applications involving extended bodily contact, medical devices and containers, or food packaging, contact AKCC. It is the responsibility of the user to determine compliance with relevant local and national standards and regulations, prior to use.

## Patent infringement

AKCC warrants only that the sale or use of ASAFLEX™ does not in itself infringe any patent relating thereto, but does not warrant against infringement by reason of its use in combination with other materials or in any process.

NO OTHER REPRESENTATION OR WARRANTIES, EXPRESSED OR IMPLIED, WHETHER ORAL OR ARISING BY USAGE OF TRADE OR COURSE OF DEALING, INCLUDING WITHOUT LIMITATION, SHALL BE GIVEN ANY LEGAL EFFECT by the provision of ASAFLEX™ or this publication. AKCC assumes no obligation or liability for injury or damage from the use of ASAFLEX™.

*ASAFLEX™ and TUFPRENET™ are trademarks of Asahi Kasei Chemicals Corporation.*

*SC™ Polymer is a trademark of PS Japan Corporation.*

Revised 2009.11.19

## Asahi Kasei Chemicals Corporation

### ◇ Synthetic Rubber Division, TPE Sales & Marketing Department 1

1-105 Kanda Jinbocho, Chiyoda-ku, Tokyo 101-8101 Japan  
TEL +81-3-3296-3252 FAX +81-3-3296-3454

**AKelastomer.com**  
Elastomers Information Central

Visit our Web site at:  
<http://www.akelastomer.com/>

